



### Analog Resistive Touch Screen Operator Interface featuring :

- 5.7"QVGA (320 x 240 Pixels) Color (256 Colors) Touch Screen
- Four Communication Ports :  
Two universal serial ports to connect PLC / Printer / Programming Port  
One Ethernet port to connect PLC / Programming Port / Remote monitoring  
One USB Port as Programming Port
- Multilanguage (Unicode) support with Windows® fonts
- Direct connection to most controller families including Modbus RTU
- Upto 65535 user definable screens (full size) or pop-up windows (partial size)
- Real Time clock and Date
- Wizards for rapid application development of standard bitmapped objects
- Real Time and Historical alarms
- Real time and Historical trending
- Recipes, Bar Graph support
- Backlight screen saver
- Windows® based programming software .....FREE!!
- IP65 design, CE / UL certification

Preliminary

# Applications :

Prizm550 can be used in different applications across many industries. Typical configurations include the following:

## 1. PLC and Drive Communication on Various Ports



## 2. Connect SCADA and I/O to Prizm

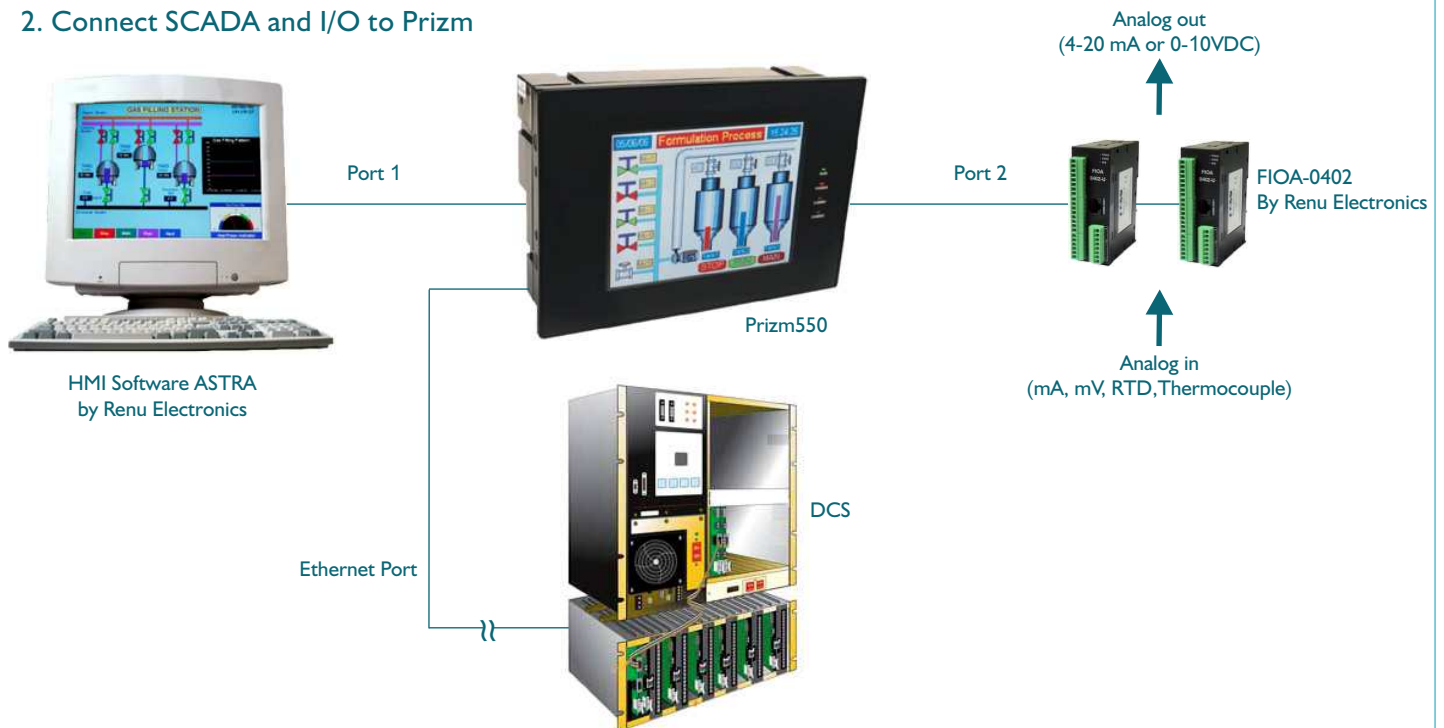

## 3. Remote Monitoring and Programming

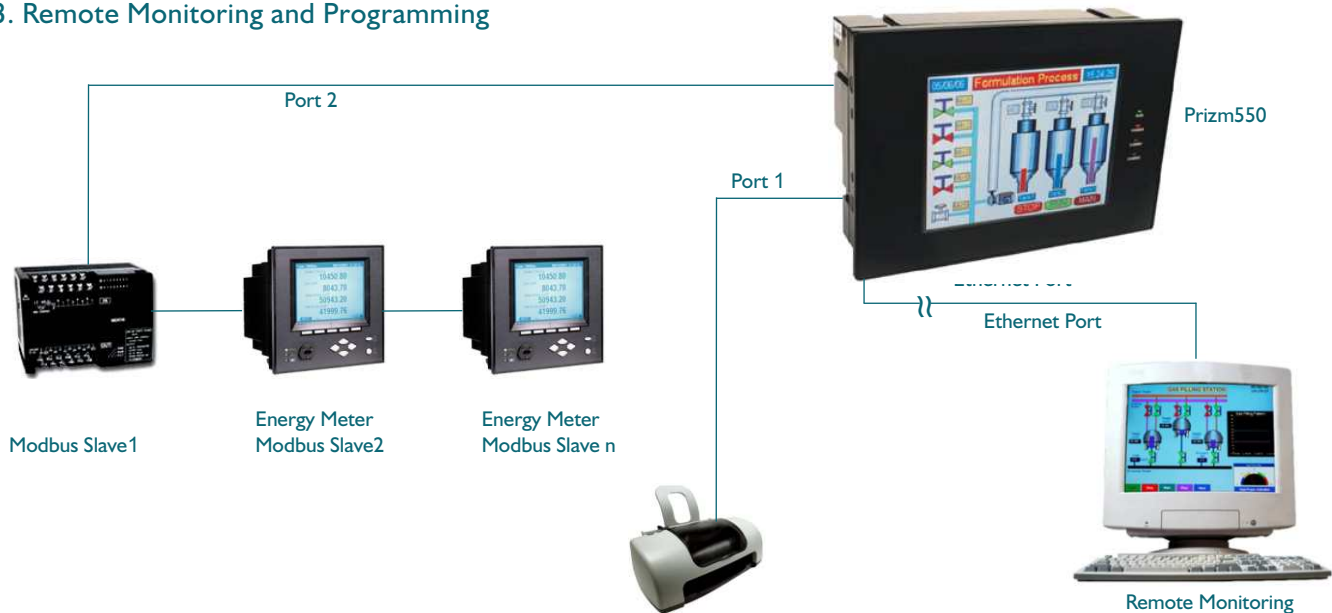

# Basic Operations :

Prizm Operations are controlled by Power-ON Tasks, Global Tasks and Screens Tasks.

Supported Tasks include:

- Go to Screen
- Go to Previous Screen
- Add a Constant to Tag
- Turn Bit On
- Toggle Bit
- Print Data
- Copy Tag to STR
- Wait
- Copy Recipe Block to PLC Block
- Copy PLC Block to Recipe Block
- Go to Next Screen
- Write Value to a Tag
- Subtract a Constant from Tag
- Turn Bit Off
- Copy Tag B to Tag A
- Set RTC
- Delay
- Copy RTC to PLC Block
- Execute PLC Logic Block

## Application Task List

Application task list includes tasks which are executed at power-on and global tasks which are executed irrespective of the active screen.

## Screen Task List

The screen task list includes tasks, which are executed only when that particular screen is active. Different set of tasks can be executed “before” the screen is shown; “while” the screen is being shown and “after” the screen is closed.

## Touch Screen Task

A list of tasks can be created which are executed upon touching an area (button) on the Prizm screen. Different set of tasks can be executed when the button is “pressed”; while the button is “held down” and “when” the button is “released”. Special tasks allow creating buttons such as numeric inputs, alarm management, data logger management etc.

## Compact Flash

Prizm550 supports Compact Flash, which is used for downloading the application into Prizm unit at sites. It can also be used to store logged data.

## Trending

User can plot graph for Engineering parameter Vs Time on Prizm screen. Multiple trends can be displayed on one screen.

## Multilanguage / Unicode Support

All the languages are supported in the Prizm unit. User can now display messages, alarms in any regional language. All Windows® fonts can also be used in an application.

## Bitmaps / Wizards

Bitmaps can be imported into the application and displayed on the Prizm screens. In addition, several wizards are supported to create commonly used objects such as Analog meters, Lamps, Buttons and Bar graphs.

## Screens

The Number of screens, which can be defined, is constrained only by the unit memory. Various types of objects can be defined on the screen such as plain text objects, Data display (coil status, register value, value dependent text), Data entry objects, Alarm objects, Bitmaps, Wizards, Date / Time etc.

## Data Entry

Data entry objects can be placed on screens. Each data entry object can have high / low limits and math function associated with it. Various types of data formats are supported including floating point data.

## Alarms

Up to 256 real time alarms can be defined in Prizm. Alarms can be displayed on the screen in formatted (user defined) columns. Alarms could also be logged and historical alarms can also be displayed. Buttons can be created to acknowledge alarm, print alarm, view next / previous alarm etc.

## Recipes

Recipes data is stored in the Prizm memory. With one button stroke, a set of data can be downloaded to the PLC. Once in the local memory, the recipes data can be edited using simple data entry objects.

## Communication Ports:

**RS232 - RS422 / RS485 / CMOS Ports:** Prizm550 has two serial communication ports. Both the ports can be used for programming of Prizm unit, printing screens, connecting to third party serial devices (barcode readers, printers etc.) or to connect to a PLC or drive. User can connect two masters simultaneously on these ports.

**Ethernet Port:** Prizm550 supports Ethernet port. It can be used to connect to a PLC and monitor machine / process status from remote location. The Ethernet port can also be used for remote programming of Prizm550.

**USB Port:** Prizm550 has USB port that can be used as programming port.

## RTC

Prizm550 has built-in RTC and Date feature which are used in real time based applications. RTC can be embedded to PLC register

# Standard Objects :

Prizm550 supports different types of objects that can be defined on the screen. Partial list of objects is as mentioned below:

## Text

User can define messages, alarms in simple text format. Four selectable font sizes are available for Prizm Fonts for simple text objects (1x, 1.5x, 2x and 4x). Prizm550 also supports all Windows® fonts and their sizes, which user can select for the application. Alarm objects can show alarm text, ON /OFF text, status etc.

## Lamps

Different types of lamps are provided in Prizm set up software to show conditions like alarms, go, no-go, ON, OFF etc. User defined images are possible for lamps.

## Analog Meters

Various analog meters are made available in Prizm setup software for graphical representation of parameters such as speed, level, temperature, electrical parameters etc. User can define scales for these analog meters as per the application requirements.

## Vector Graphics

Different vector graphics are available such as rectangle, ellipse, lines etc.

## Buttons

Various types of buttons are provided in Prizm setup software required for different applications. Tasks can be assigned to these buttons such as wizard control, alarm management etc.

## Bar graphs

Prizm550 supports different types of bargraphs like, top to bottom, bottom to top, left to right and right to left to denote parameters such as temperature, pressure, level etc. Multiple bargraphs are possible on one screen. User can associate actual field value in digital format to these bar graphs.

## Pop-up Screens / Keypads

Prizm550 has pop-up keypads such as numeric keypad for easy data entry which optimizes the use of Prizm display.

## Bitmaps

Different bitmaps can be embedded on the Prizm screen. Transparent buttons can be used for data entry and set points on bitmap images.

*More objects are being added. Contact factory for details.*

## Specifications :

Power	: + 24V DC $\pm$ 10%, 10 W max.	USB Port	: As programming port
Bezel	: IP 65 rated Bezel	STN Life	: 50000 Hrs.
Operating Temperature	: 0°C to 50°C	CPU Speed	: 200 Mhz
Storage Temperature	: -20°C to 80°C	Immunity to ESD	: Level 3 as per IEC1000-4-2
Touch Screen	: Analog resistive type	Immunity to Transients	: Level 3 as per IEC1000-4-4
Humidity	: 10% to 85% (Non-Condensing)	Immunity to Radiated RF	: Level 3 as per IEC1000-4-3
Communication Ports	: Two serial ports. PLC port for connecting to a PLC. Second port for programming of Prizm, connecting to a serial printer, a third party device and another PLC or Drive. (RS232/RS422/RS485/CMOS levels supported)	Immunity to Conducted RF	: Level 3 as per IEC1000-4-6
		Emissions	: EN55011 CISPR A
		In-Rush Current	: 1 A
Ethernet Port	: For connecting to a PLC, programming of Prizm, a third party device, Drive or remote monitoring. ( 10 / 100 MBPS )		

## Dimensions :

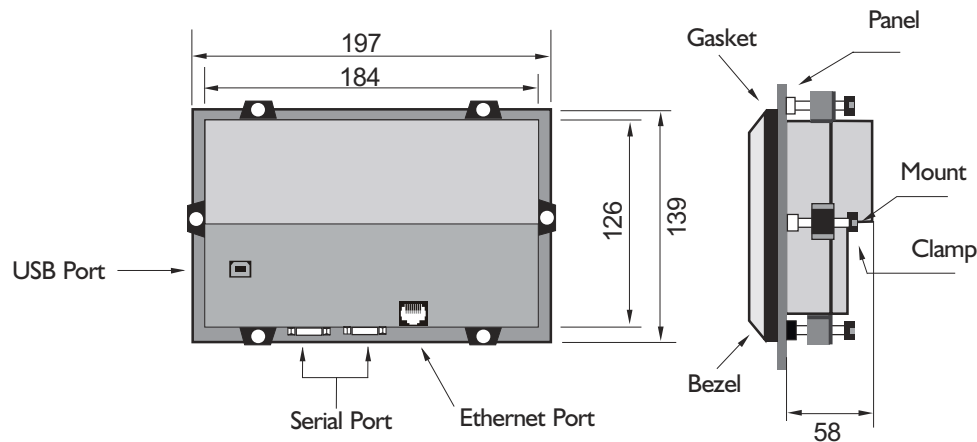

All dimensions are in mm.

## Models:

Part No.	Ethernet Port	USB Port	Serial Port	Compact Flash	RTC	Power
PZM-550-N-24-B	Yes	Yes	2	No	Yes	+24 VDC
PZM-550-E-24-B	Yes	Yes	2	Yes	Yes	+24 VDC

**SIAM** Control & Automation

**SIAM CONTROL & AUTOMATION LTD.**  
 27 Bartholemews Lane ,Bromsgrove, Worcs , B61 0AY, UK  
 Tel : +44 1527 578376 , Fax : +44 1527 477451 ,  
 Mobile : +44 7917 330075  
 Email : colin@siamcontrol.co.uk , sales@siamcontrol.co.uk  
[www.siamcontrol.co.uk](http://www.siamcontrol.co.uk)

